



**HAVE QUESTIONS OR
NEED ADDITIONAL SUPPORT?**

support@mdttac.com
+1 (604) 393-0800



BOTTOM METAL INSTALLATION

1. Ensure your Ruger Barreled Action is safe & unloaded and remove from the factory stock.
2. Drop into the TIMBR Stock.
3. Remove plastic hex nuts from action screws on the bottom metal.
4. Place the spacers (**Included with the chassis box**) into the action screw holes in the stock.
5. Insert the bottom metal and action screws into the stock (**1/4-28 Flat head screw in the front. The 1/4-28 Button head screw in the rear.**)
6. Before you Torque the action screws make sure to push the bottom metal forward to ensure proper alignment.
7. Tighten the action screws using a **5/32" Hex Key** or Torque wrench with a **5/32" Hex Bit (Torque to 65 inch-pounds).**
8. Install the magazine latch (**See mag latch installation**)
9. Use a phillips screws driver to install the bottom metal retaining screw (#8-15 x 0.5" FHTFS) Hand tight or torque to **15 inch-pounds.**
 - A. Note: Only torque once you have confirmed magazine can be inserted.

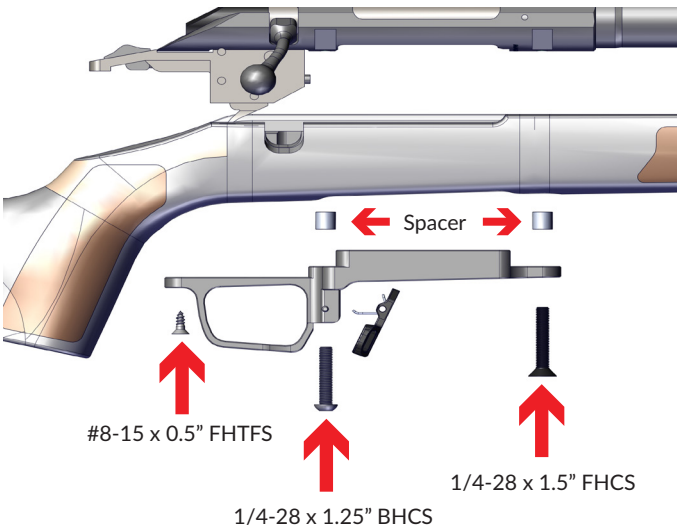

MAGAZINE LATCH INSTALLATION

1. Position spring within the back side of the magazine latch, ensuring that the looped end of the spring is facing upwards.
2. Insert the dowel pin into the side of the magazine latch & spring until it sits flush with the magazine latch.
3. Take the magazine latch & spring and position it in the bottom metal ensuring that the assembly pin lines up with the magazine latch pin hole.
4. Using a 1/8" pin punch, start pushing out the dowel pin in exchange for the pin punch making sure to not pull out the pin punch once the assembly pin has been removed.
5. Using a small hammer, start inserting the magazine latch pin (Looks like a mini bar bell) into the magazine latch pin hole displacing the 1/8" pin punch until it is completely pushed out.
6. Once the magazine latch pin has been installed, make sure that it is evenly seated side to side.

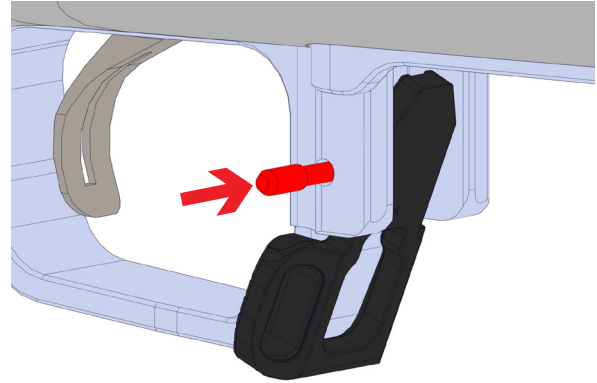

SUPPLIED HARDWARE

- 1/4-28 x 1.5" FHCS
- 1/4-28 x 1.25" BHCS
- Magazine Lock Lever
- Spring
- Ambidextrous latch
- Dowel Pin
- Magazine Lock Pin
- Spacers
- #8-15 x 0.5" FHTFS (Flat Head Thread Forming Screw)

TOOLS REQUIRED

- 5/32 Hex Drive
- Torque Wrench
- Phillips Head Screwdriver
- 1/8" Pin Punch

NOTE

When metal & polymer magazines are over inserted into the action, they can block the bolt from cycling. Make sure to only push up till you hear it click into the mag latch. This appears to be limited to the Ruger American Gen 1 actions and is less of an issue on the Gen 2 actions due to the difference in bolt geometry.

WANT TO LEARN MORE?
CHECK OUT OUR INSTALL VIDEO

